

1080 SERIES

10.0x8mm PITCH WIRE TO BOARD CONNECTOR

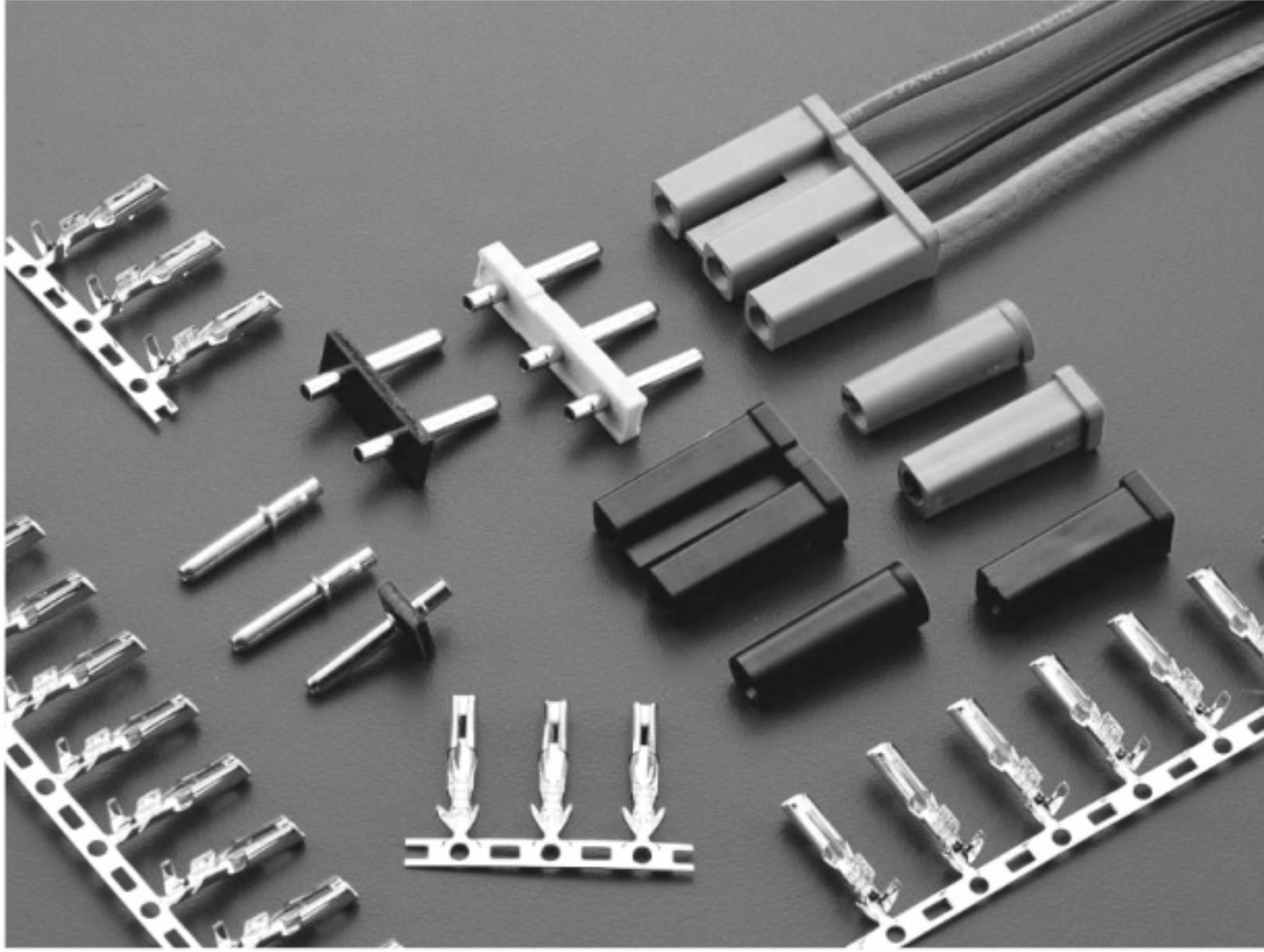

Specifications

Current rating: 5A AC,DC

Voltage rating: 250V AC,DC

Temperature range: -25°C to +85°C
(including temperature rise)

Contact resistance: Initial value/ 10m Ω Max.
After environmental testing/20m Ω Max.

Insulation resistance: 1000M Ω Min.

Withstanding voltage: 1500V AC/minute

Applicable wire: AWG#18-#22

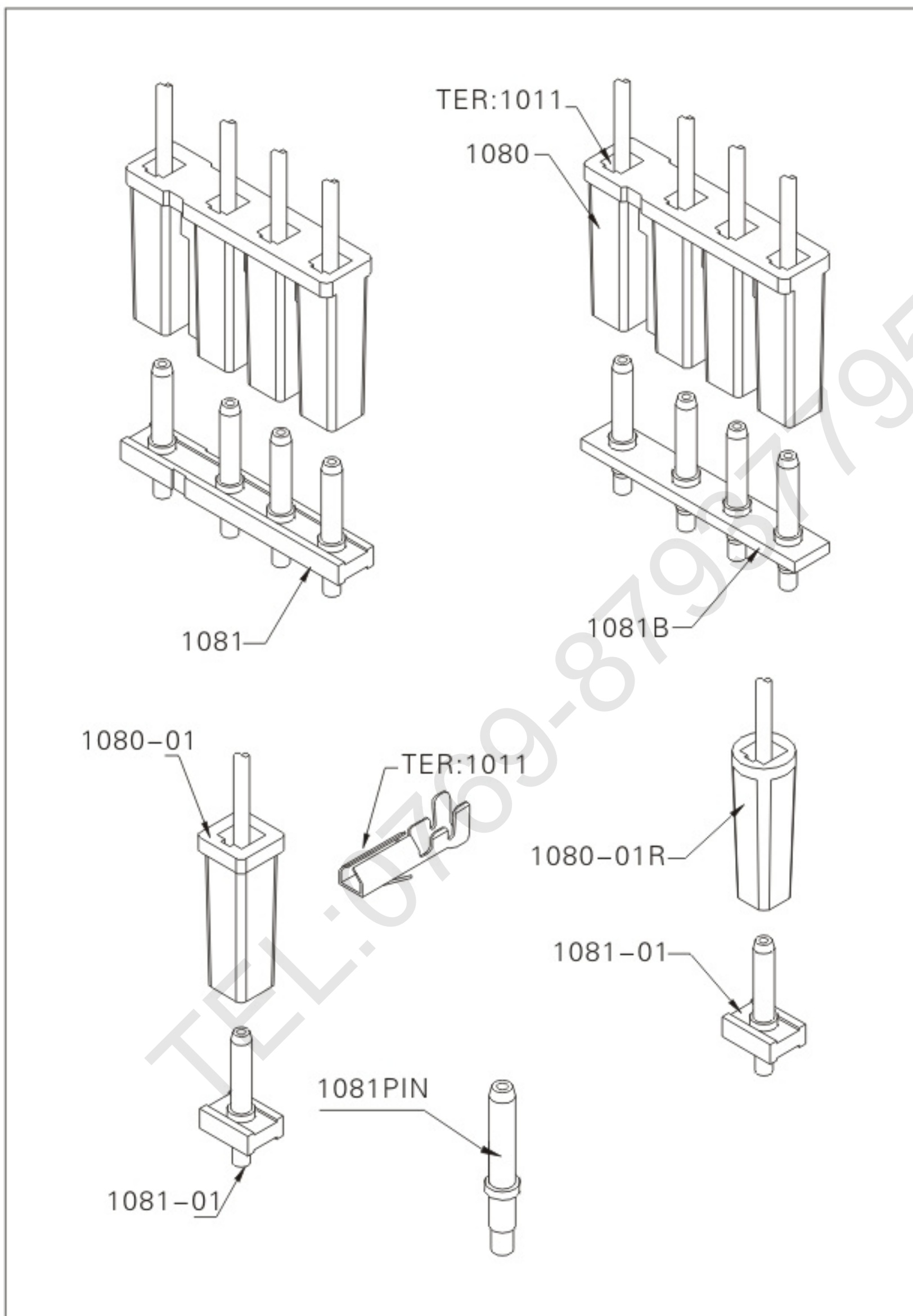

Assembly layout

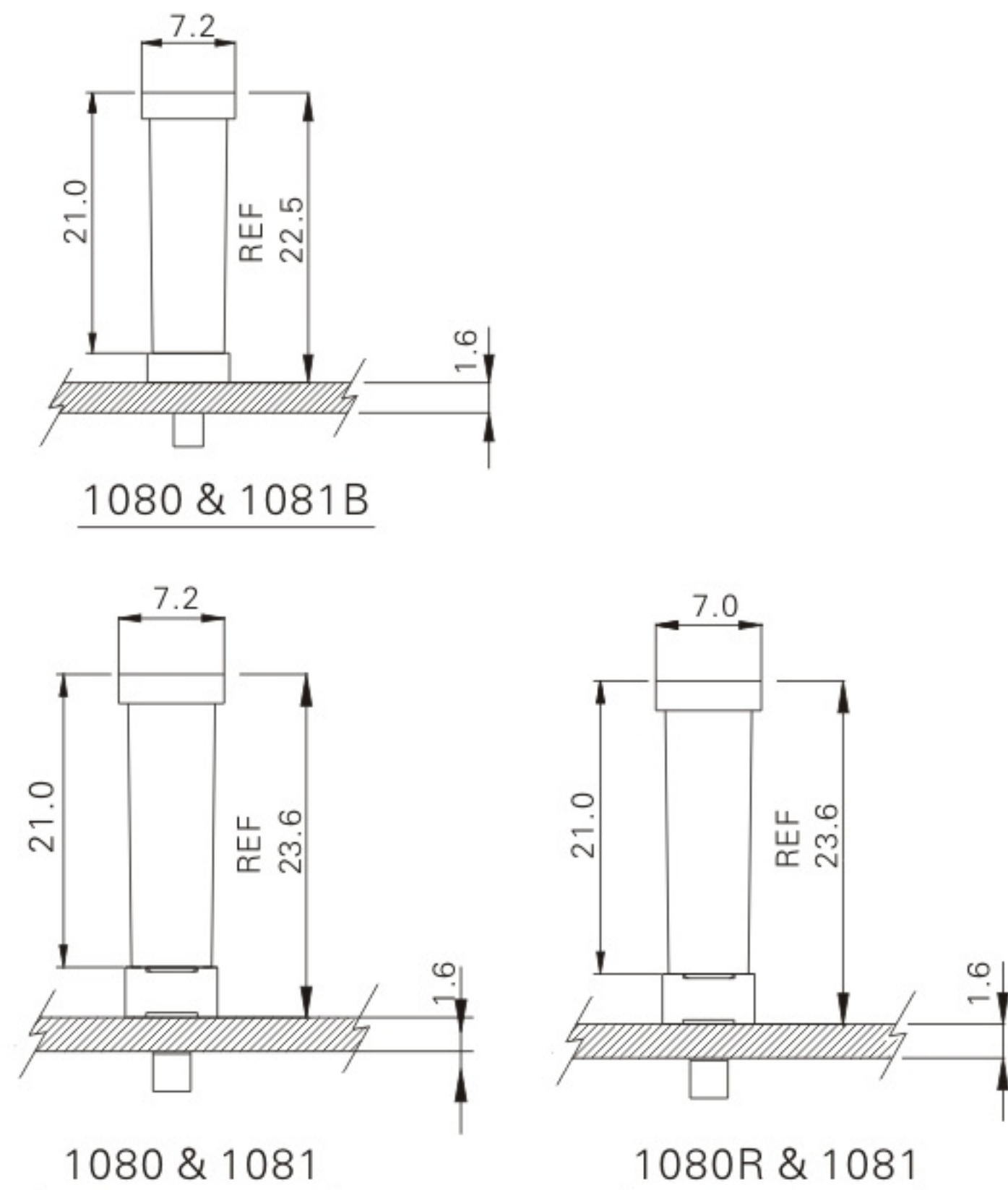

1080-01L 1080-01R (crimp housing)

Reference Informations:

*Mat'l: Nylon UL94V-0 Black Color or Gray Color

*Mates: 1011 1013 series Terminal

*Accepts: 1081 series Wafer

1080-01L SERIES

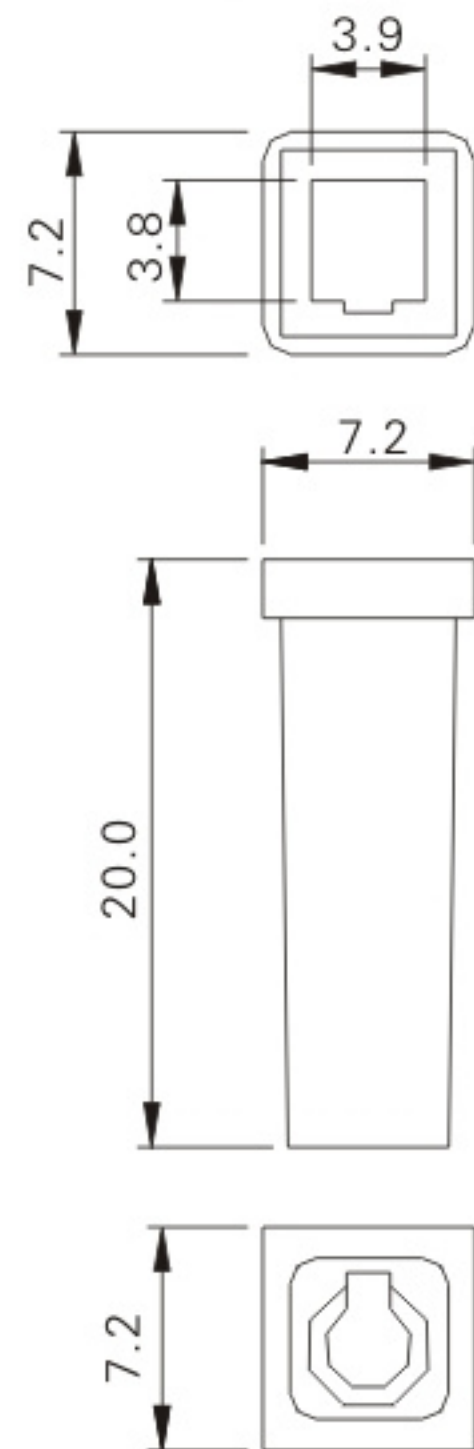

1080-01R SERIES

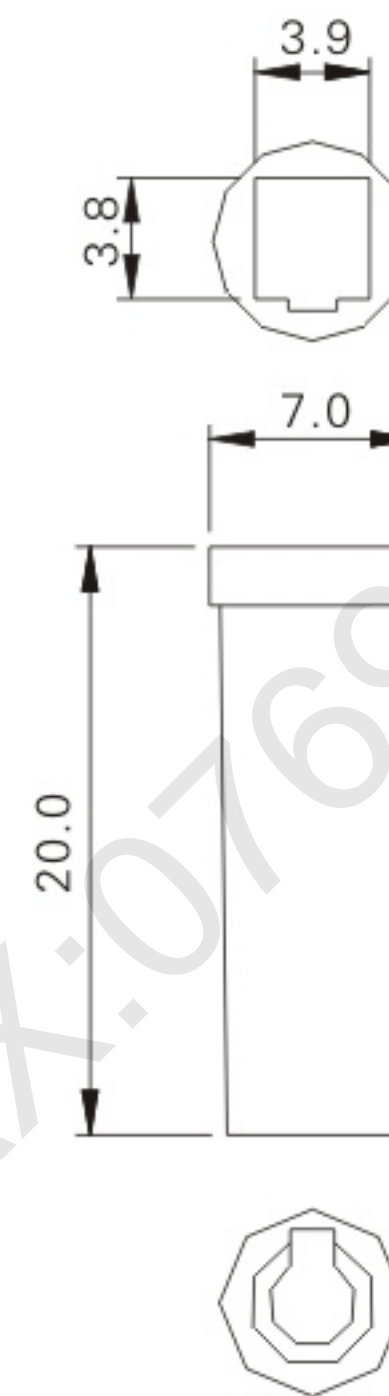

1081 1081B (10x8mm pitch wafer)

Reference Informations:

1081

*Mates: Body: Nylon 66 UL94V-0

Pins: Brass Tin Plated

*Mates With 1080 series Housing

*Accepts With: 1011 1013 series Terminal

1081B

*Mat'l: Bakelite

*Mates With: 1080 series Housing

*Accepts With: 1011 1013 series Terminal

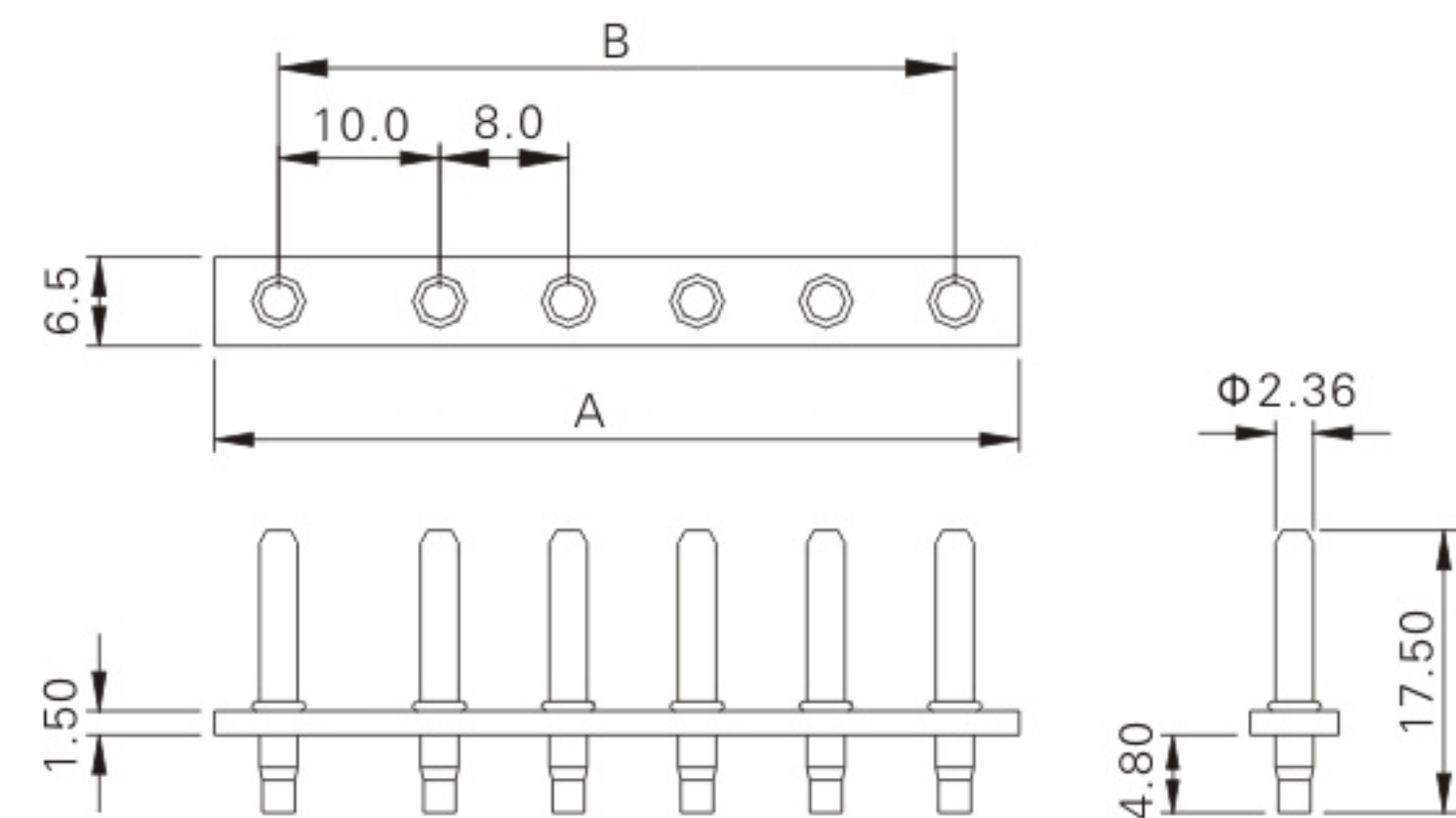
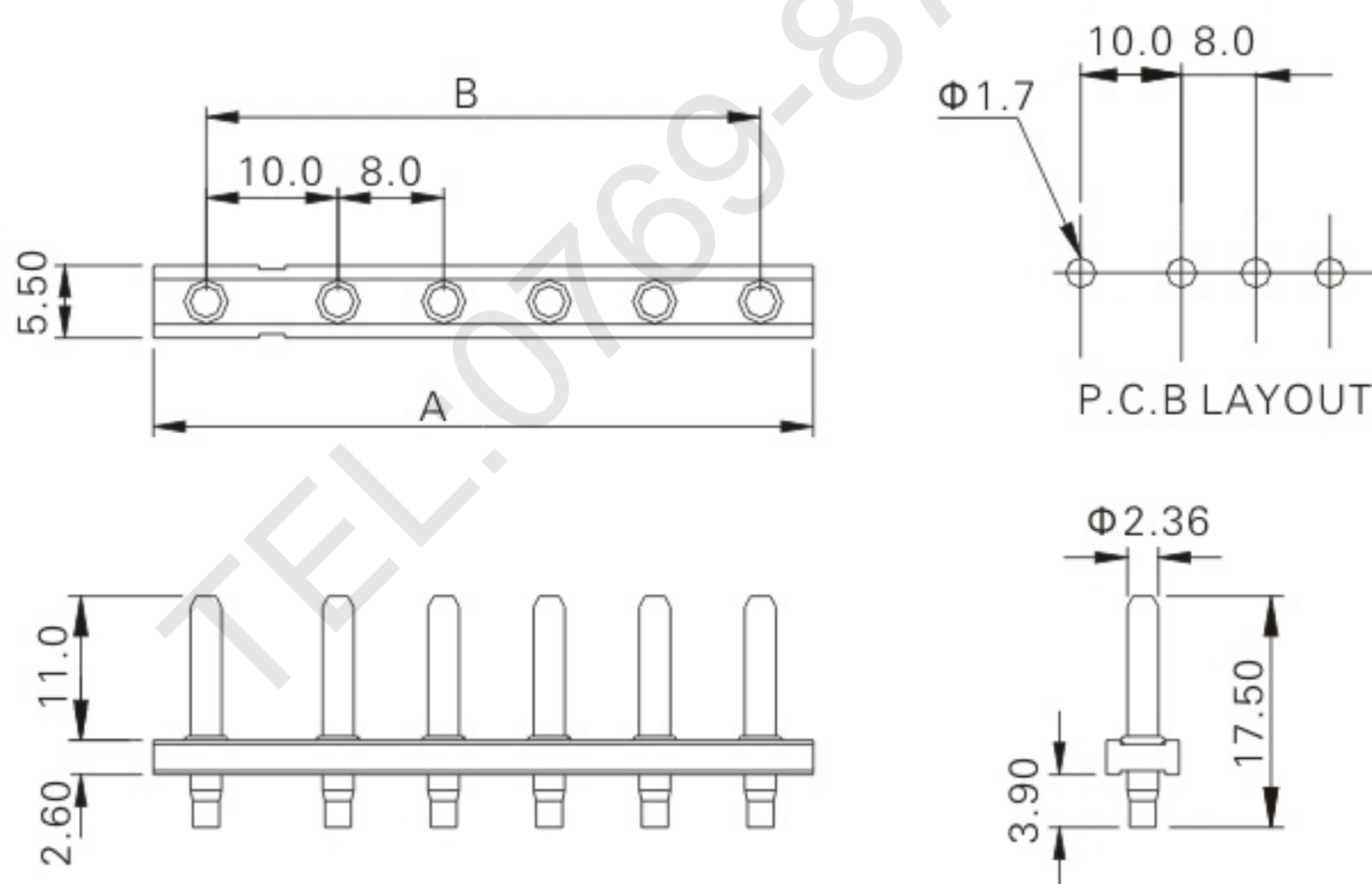

Ordering Information & Dimensions

Circuits	Part No.	DIM.(mm)	
		A	B
01	1081-01	6.5	/
02	1081-02	18.0	10.0
03	1081-03	26.0	18.0
04	1081-04	34.0	26.0
05	1081-05	42.0	34.0
06	1081-06	50.0	42.0

Ordering Information & Dimensions

Circuits	Part No.	DIM.(mm)	
		A	B
01	1081B-01	8.0	/
02	1081B-02	18.0	10.0
03	1081B-03	26.0	18.0
04	1081B-04	34.0	26.0
05	1081B-05	42.0	34.0
06	1081B-06	50.0	42.0

1011H 1011SL 1013 (10x8mm pitch crimp terminal)

Reference Informations:

- *Thickness: 0.25mm
- *Mat'l: Brass Tin plated
- *Mates With: 1080 series Housing

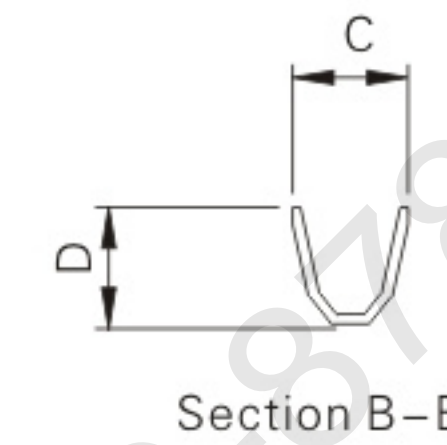
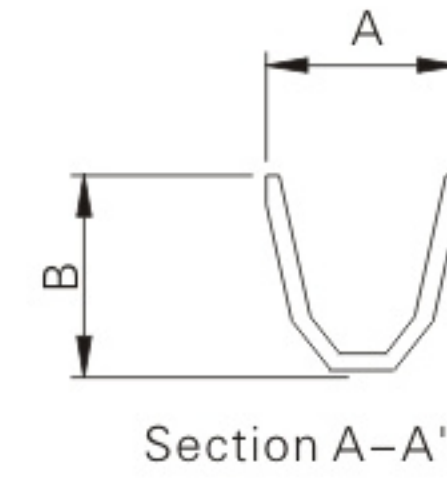
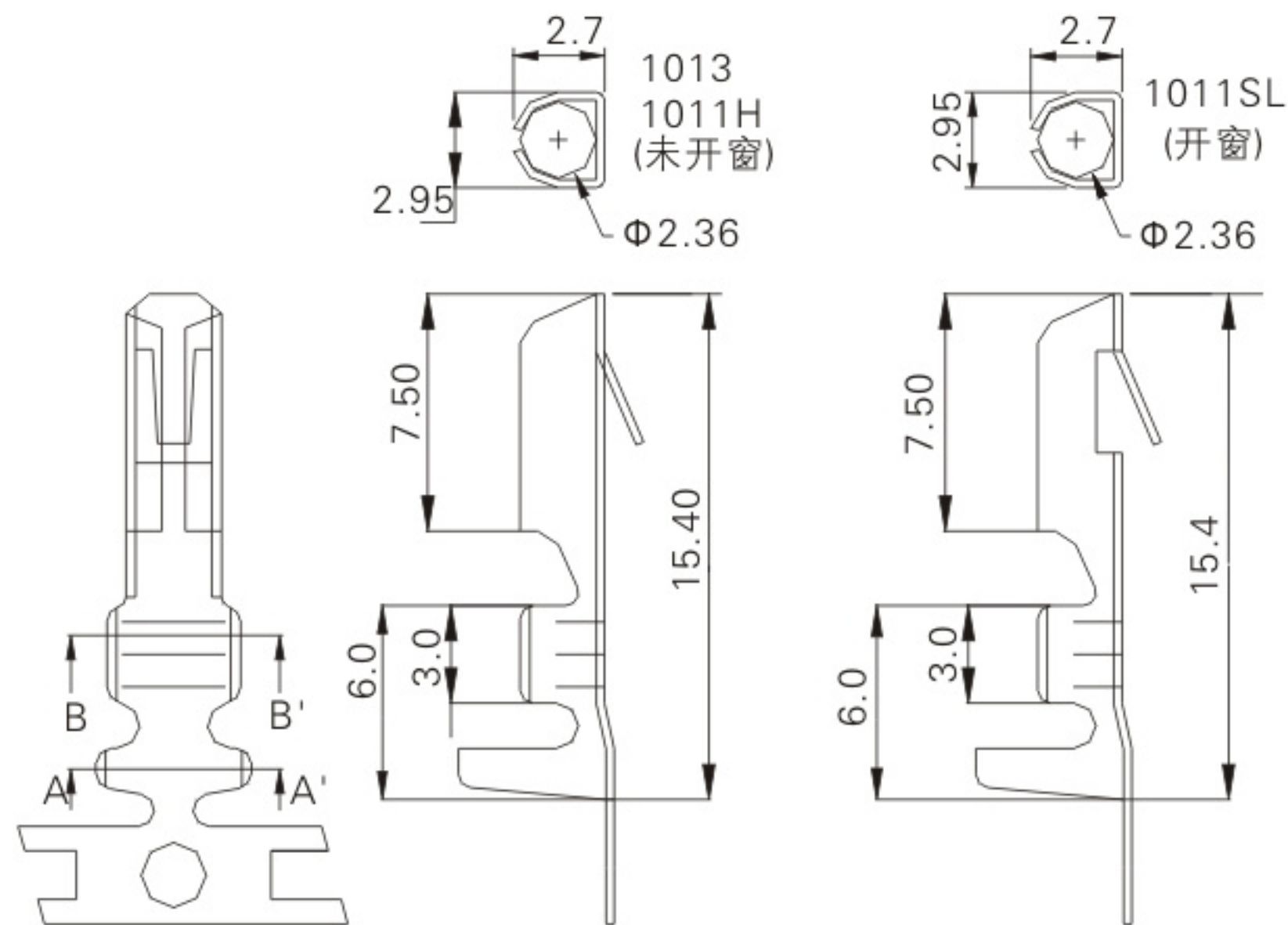

Ordering Information & Dimensions

Circuits	Part No.	DIM.(mm)			
		A	B	C	D
02	1011H 1011SL	3.8	3.5	2.8	2.5
03	1013	4.6	4.0	2.4	2.7

Ordering Information & Specifications

Unit: mm

Part No.	Wire Range	Insulation O.D.	Material	Finish	Qty/reel
1011H / 1011SL	AWG#18-#22	Φ2.54mm max	Brass	Tin-plated	6,000
1013	AWG#18-#22	Φ2.80mm max	Brass	Tin-plated	7,000

1080 (10x8mm pitch crimp housing)

Reference Informations:

- *Mat'l: Nylon66 UL 94V-0
- *Mates: 1011 1013 series Terminal
- *Accepts With: 1081 series Wafer

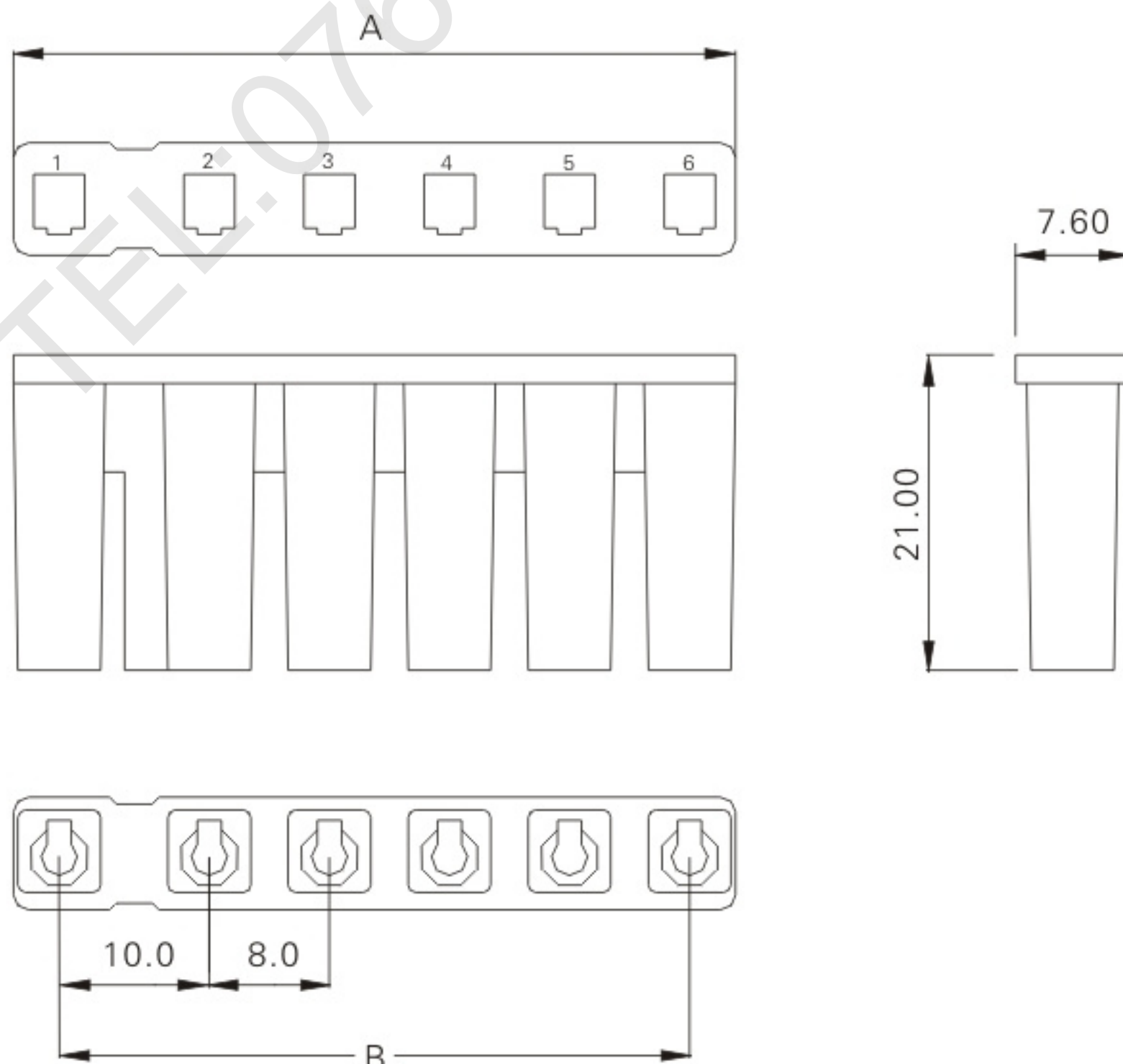

Ordering Information & Dimensions

Circuits	Part No.	DIM.(mm)	
		A	B
01	1080-01	7.2	
02	1080-02	16.0	10.0
03	1080-03	24.0	18.0
04	1080-04	32.0	26.0
05	1080-05	40.0	34.0
06	1080-06	48.0	42.0

1081-01 PIN (Φ2.36 pin)

Reference Informations:

*Thickness: 0.3mm

*Mat'l: Brass Tin Plated

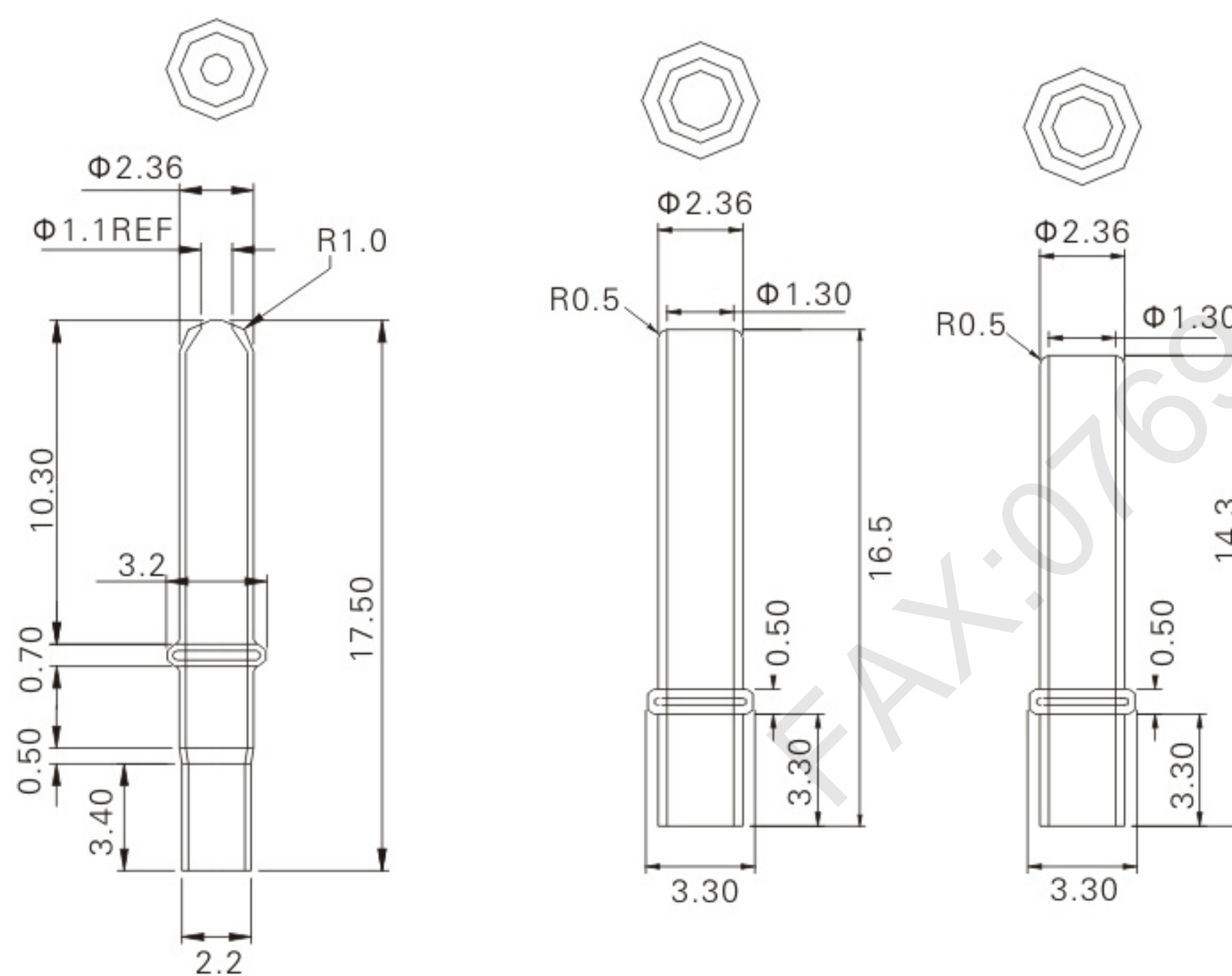

TEL:0769-87937795