

Specifications

Current rating: 3A AC,DC

Voltage rating: 250V AC,DC

Temperature range: -25°C to + 85°C
(including temperature rise)

Contact resistance: Initial value/10m Ω Max.
After environmental testing/20m Ω Max.

Insulation resistance: 1000 M Ω Min.

Withstanding voltage: 800V AC/minute

Applicable wire: AWG#24-28

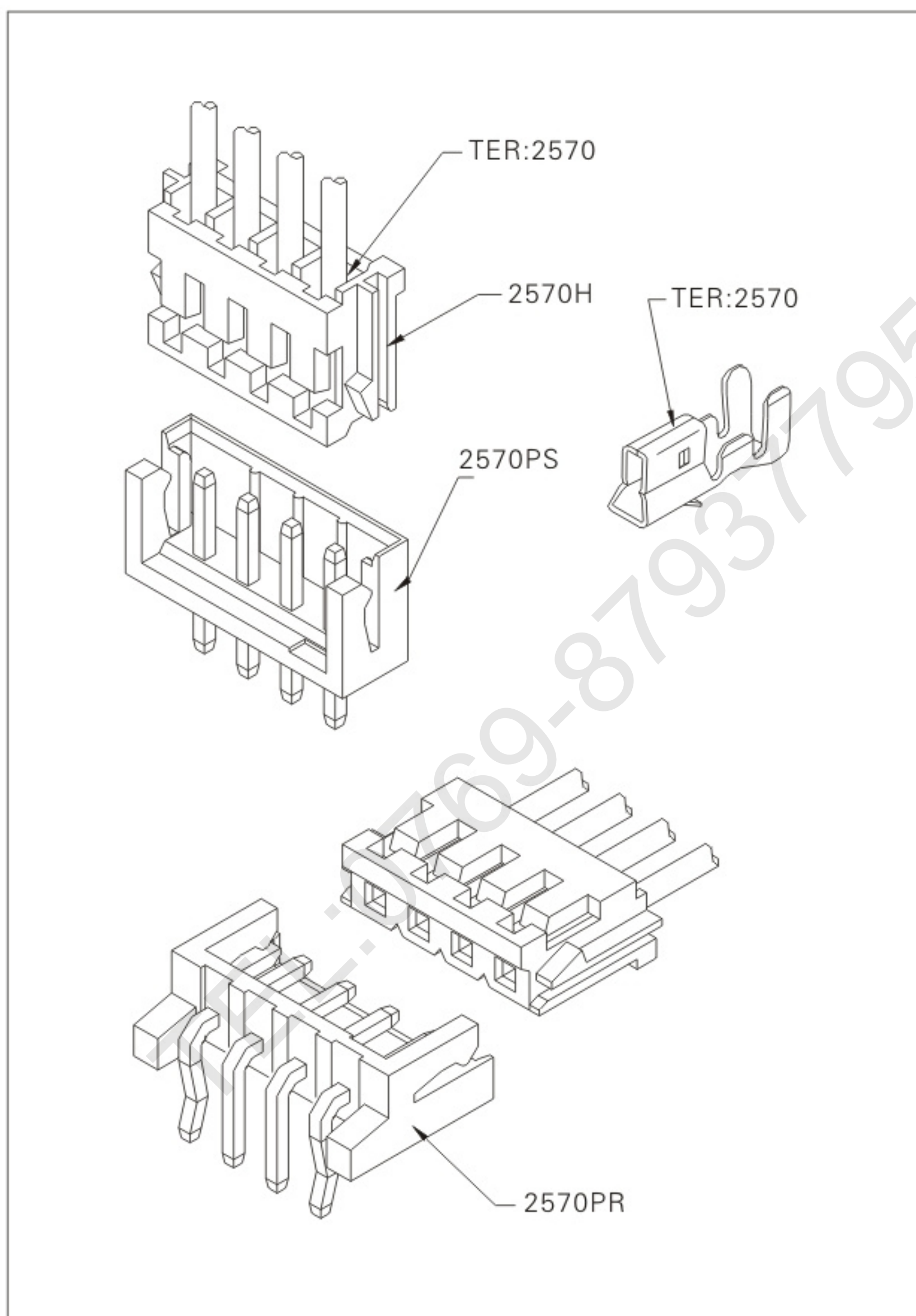

Assembly layout

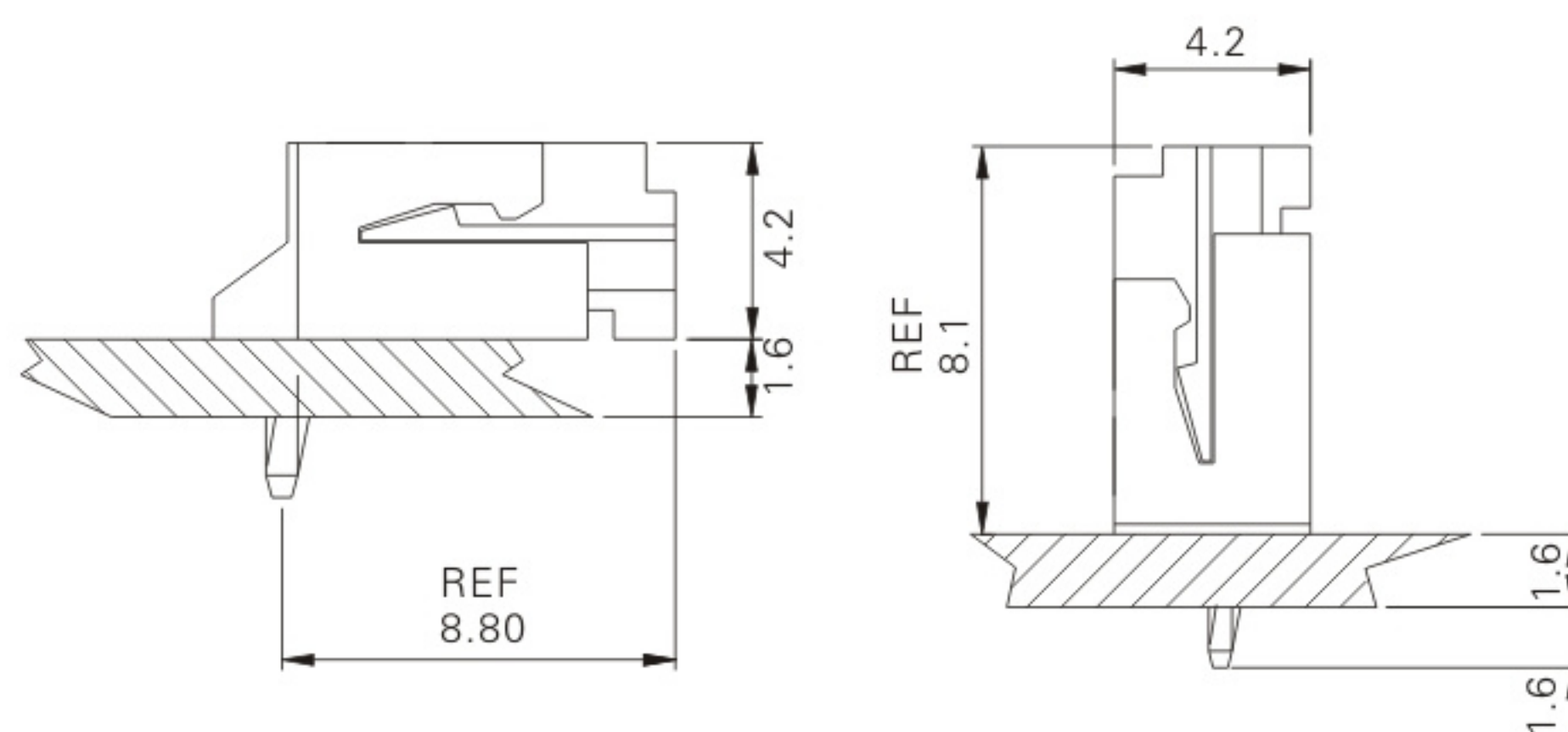

2570-T (2.50mm pitch crimp terminal)

Reference Informations:

- *Thickness: 0.2mm
- *Mat'l: Phosphor Bronze Tin Plated
- *Mates With: 2570H series Housing
- *Accepts With: 2570PS & 2570PR series Wafer
- *Accepts With: 0.64mm(0.25") Square Pin

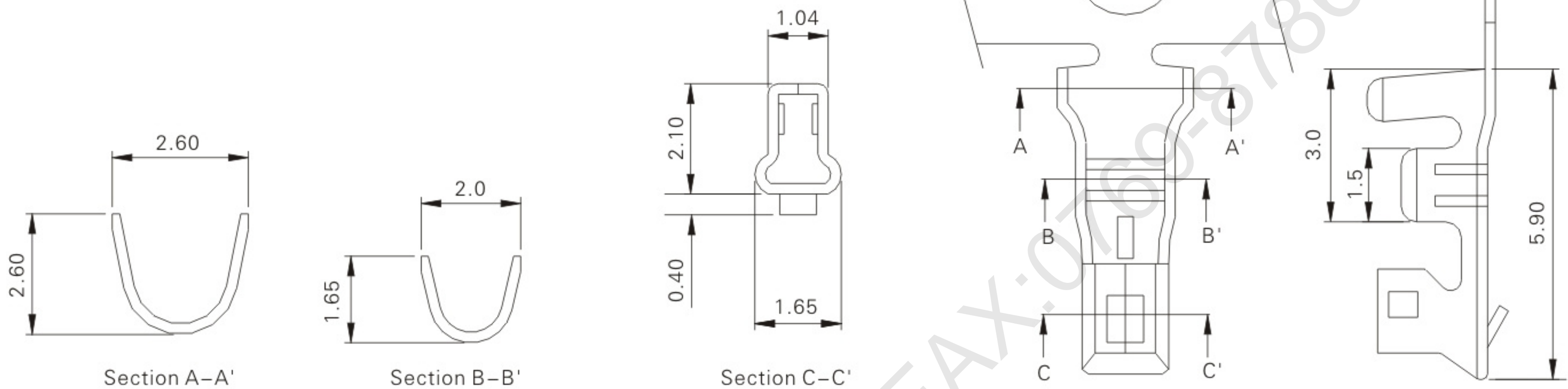

Ordering Information & Specifications

Unit: mm

Part No.	Wire Range	Insulation O.D.	Material	Finish	Qty/reel
2570P	AWG#24-28	1.8mm max	Phosphor broze	Tin-plated	10,000

2570H-NP (2.50mm pitch crimp housing)

Reference Informations:

- *Mat'l: Nylon 66 UL94V-0
- *Mates: 2570-T series Terminal
- *Accepts With: 2570PS & 2570PR series Wafer

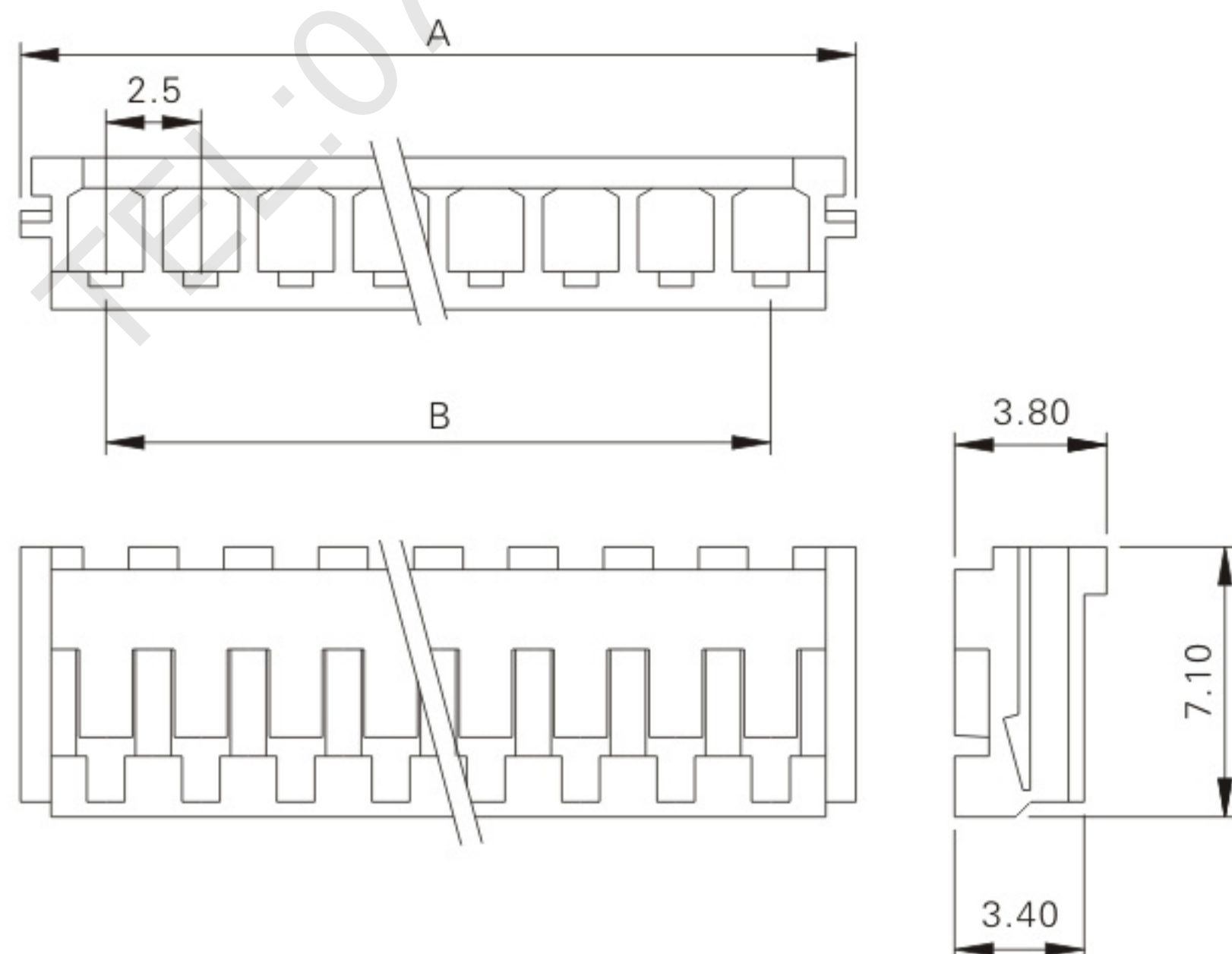

Ordering Information & Dimensions

Circuits	Part No.	DIM.(mm)	
		A	B
02	2570H-02P	7.00	2.5
03	2570H-03P	9.50	5.0
04	2570H-04P	12.0	7.5
05	2570H-05P	14.5	10.0
06	2570H-06P	17.0	12.5
07	2570H-07P	19.5	15.0
08	2570H-08P	22.0	17.5
09	2570H-09P	24.5	20.0
10	2570H-10P	27.0	22.5
11	2570H-11P	29.5	25.0
12	2570H-12P	32.0	27.5
13	2570H-13P	34.5	30.0
14	2570H-14P	37.0	32.5
15	2570H-15P	39.5	35.0

2570PS-NP (2.5mm pitch 180° wafer)

Reference Informations:

*Mat'l:Body: Nylon 66 UL94V-0

Pins: Brass Tin Plated

*Mates With: 2570H series Housing

*Accepts With: 2570-T series Terminal

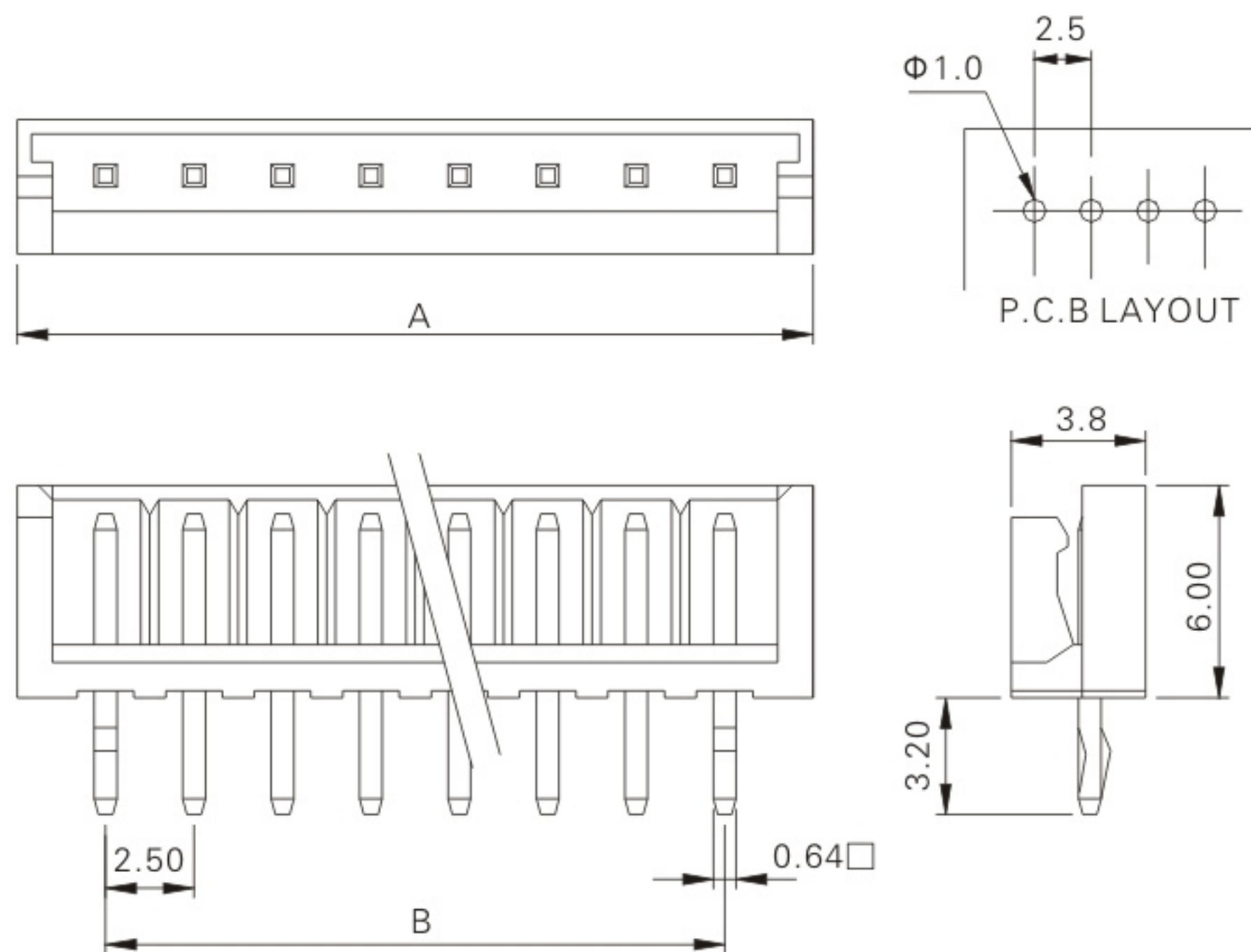

Ordering Information & Dimensions

Circuits	Part No.	DIM.(mm)	
		A	B
02	2570PS-02P	7.5	2.5
03	2570PS-03P	10.0	5.0
04	2570PS-04P	12.5	7.5
05	2570PS-05P	15.0	10.0
06	2570PS-06P	17.5	12.5
07	2570PS-07P	20.0	15.0
08	2570PS-08P	22.5	17.5
09	2570PS-09P	25.0	20.0
10	2570PS-10P	27.5	22.5
11	2570PS-11P	30.0	25.0
12	2570PS-12P	32.5	27.5
13	2570PS-13P	35.0	30.0
14	2570PS-14P	37.5	32.5
15	2570PS-15P	40.0	35.0

2570PR-NP (2.5mm pitch 90° wafer)

Reference Informations:

*Mat'l:Body: Nylon 66 UL94V-0

Pins: Brass Tin Plated

*Mates With: 2570H series Housing

*Accepts With: 2570-T series Terminal

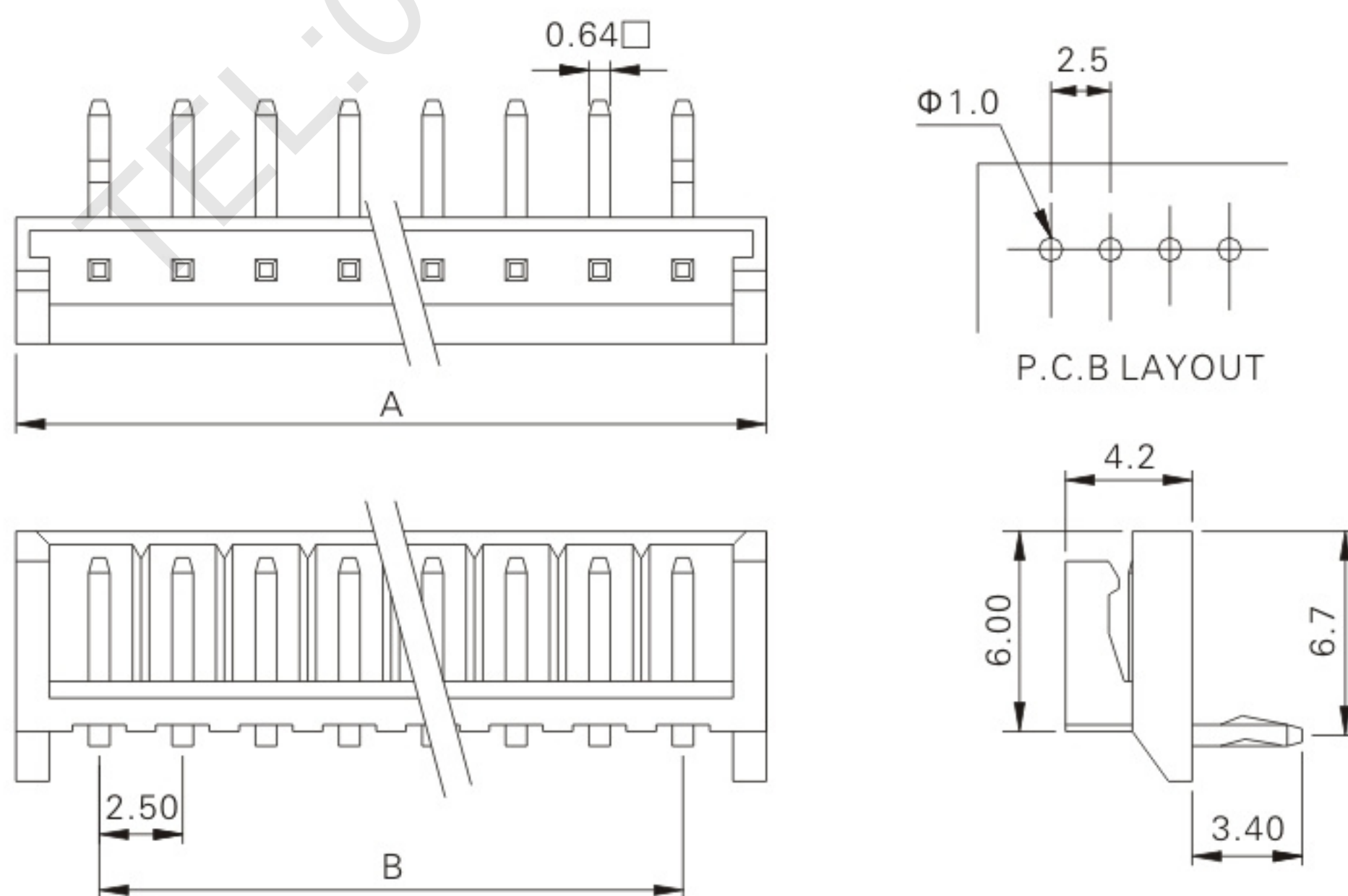

Ordering Information & Dimensions

Circuits	Part No.	DIM.(mm)	
		A	B
02	2570PR-02P	7.5	2.5
03	2570PR-03P	10.0	5.0
04	2570PR-04P	12.5	7.5
05	2570PR-05P	15.0	10.0
06	2570PR-06P	17.5	12.5
07	2570PR-07P	20.0	15.0
08	2570PR-08P	22.5	17.5
09	2570PR-09P	25.0	20.0
10	2570PR-10P	27.5	22.5
11	2570PR-11P	30.0	25.0
12	2570PR-12P	32.5	27.5
13	2570PR-13P	35.0	30.0
14	2570PR-14P	37.5	32.5
15	2570PR-15P	40.0	35.0