

4001MH/4001MCH SERIES

3.50mm PITCH WIRE TO WIRE CONNECTOR

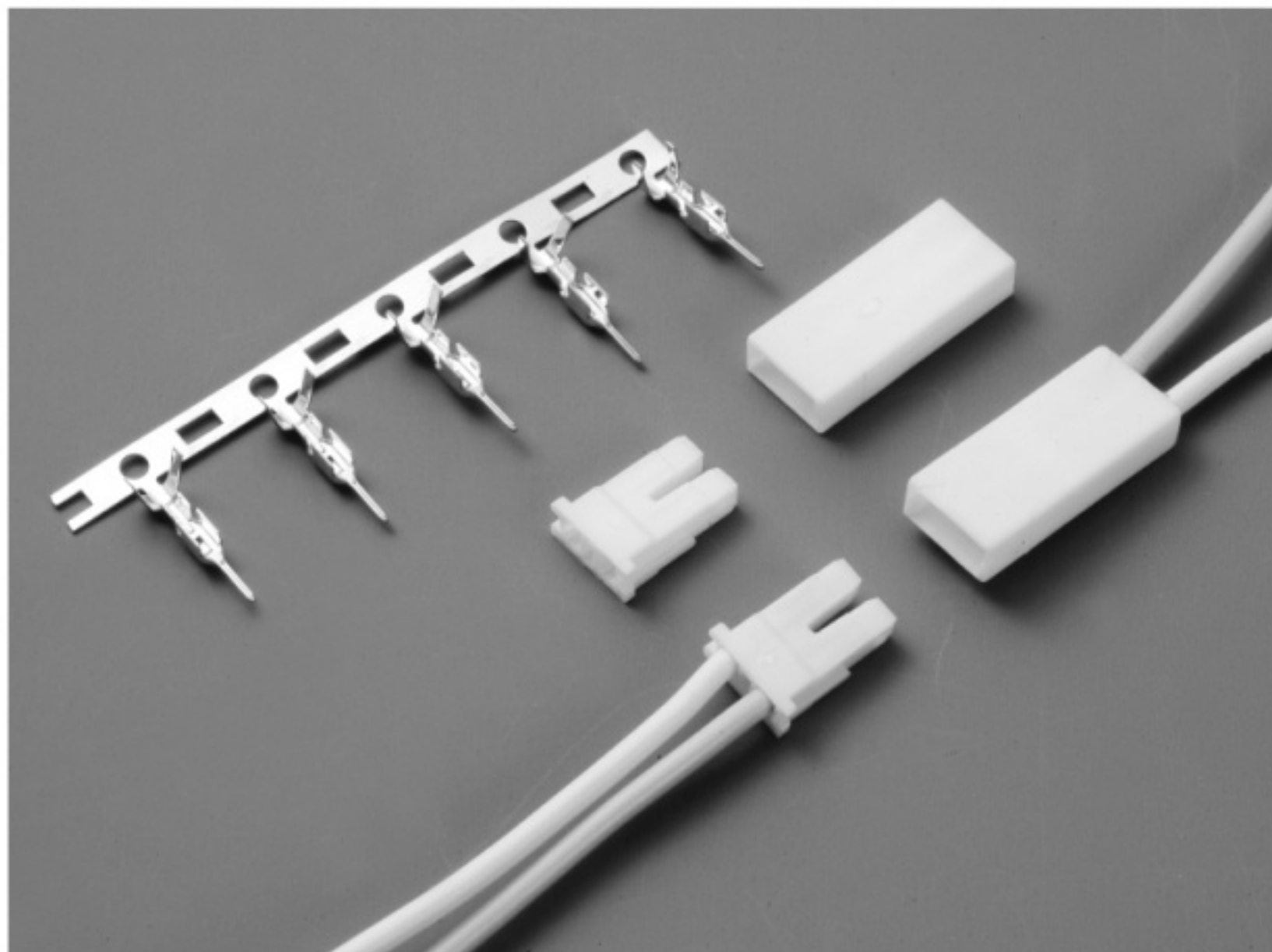

Specifications

Current rating: 3A AC,DC

Voltage rating: 250V AC,DC

Temperature range: -25°C to +85°C
(including temperature rise)

Contact resistance: Initial value/ 10m Ω Max.
After environmental testing/20m Ω Max.

Insulation resistance: 500M Ω Min.

Withstanding voltage: 1500V AC/minute

Applicable wire: 4001MT: AWG#24-#28

4001MCT:AWG#22-#28

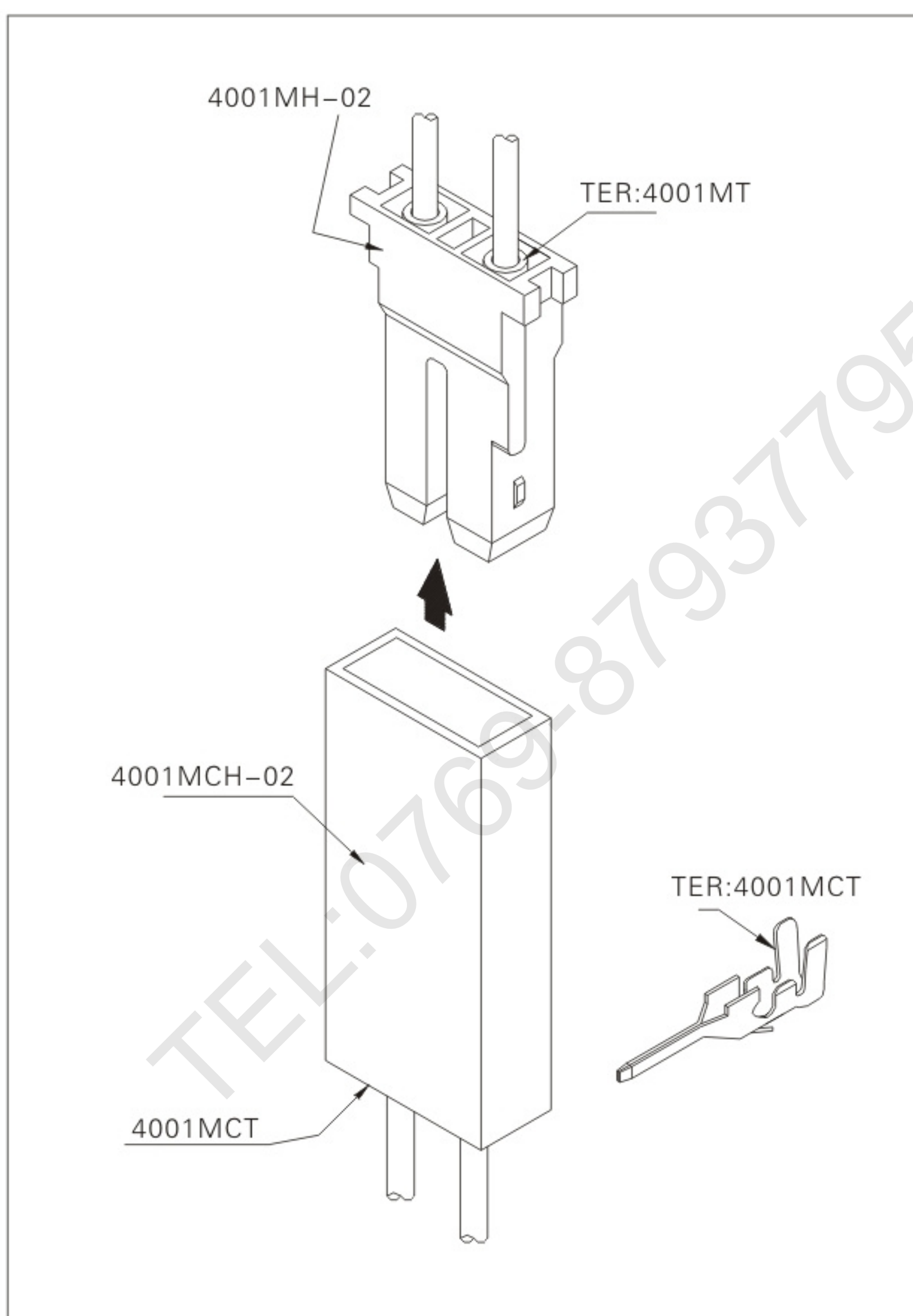

Assembly layout

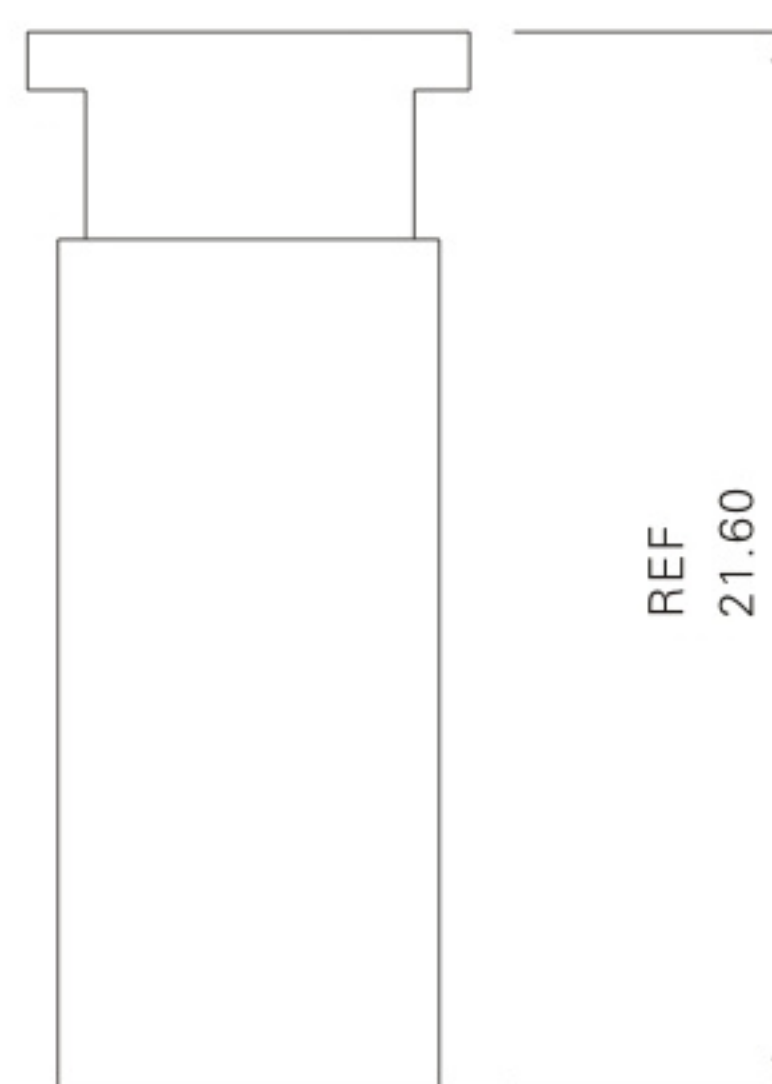

WIRE TO WIRE TYRE

4001MT (3.50mm pitch crimp terminal)

Reference Informations:

- *Thickness: 0.2mm
- *Mat'l: Phosphor Bronze Tin Plated
- *Mates With: 4001MH series Housing
- *Accepts With: 4001MCT series Terminal

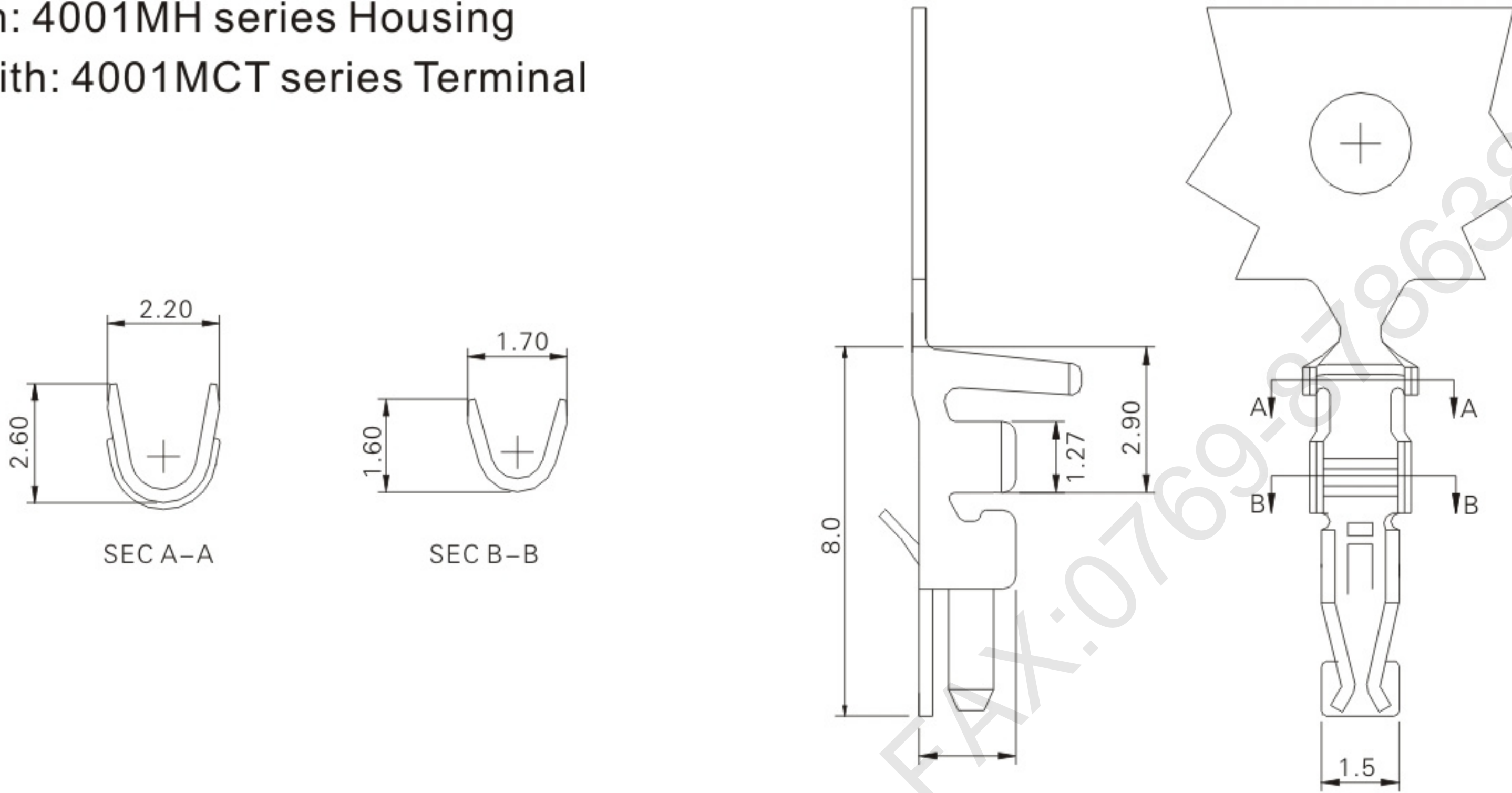

Ordering Information & Specifications

Unit: mm

Part No.	Wire Range	Insulation O.D.	Material	Finish	Qty/reel
4001MT	AWG#24-#28	1.7mm max	Phosphor bronze	Tin-plated	10,000

4001MH-02 (3.50mm pitch crimp housing)

Reference Informations:

- *Mat'l: Nylon 66 UL94V-0
- *Mates With: 4001MT series Terminal
- *Mates With: 4001MCH series Housing

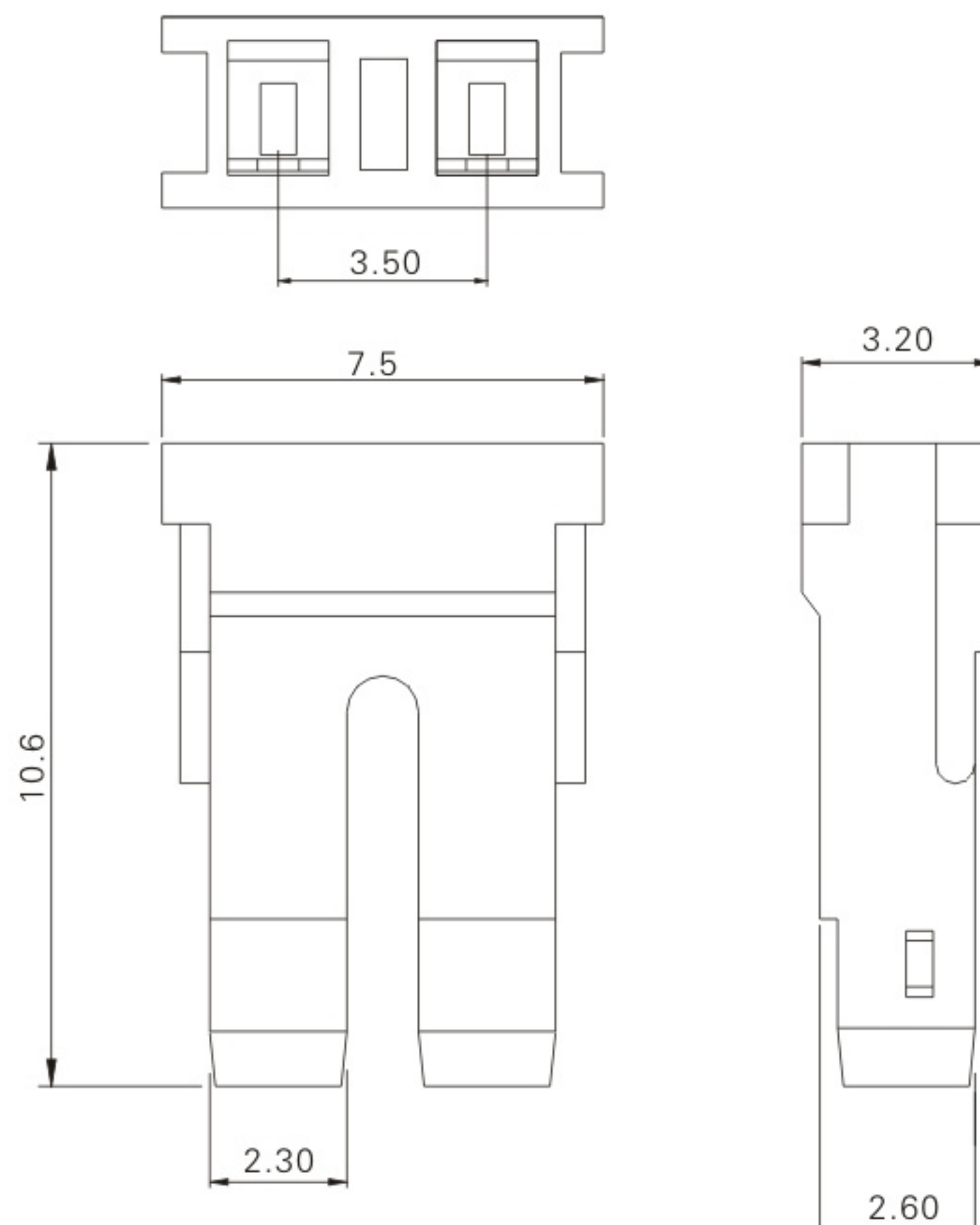

4001MCT (3.50mm pitch crimp terminal)

Reference Informations:

- *Thickness:0.2mm
- *Mat'l: Phosphor Bronze Tin Plated
- *Mates With: 4001MCH series Housing
- *Accepts With: 4001MT series Terminal

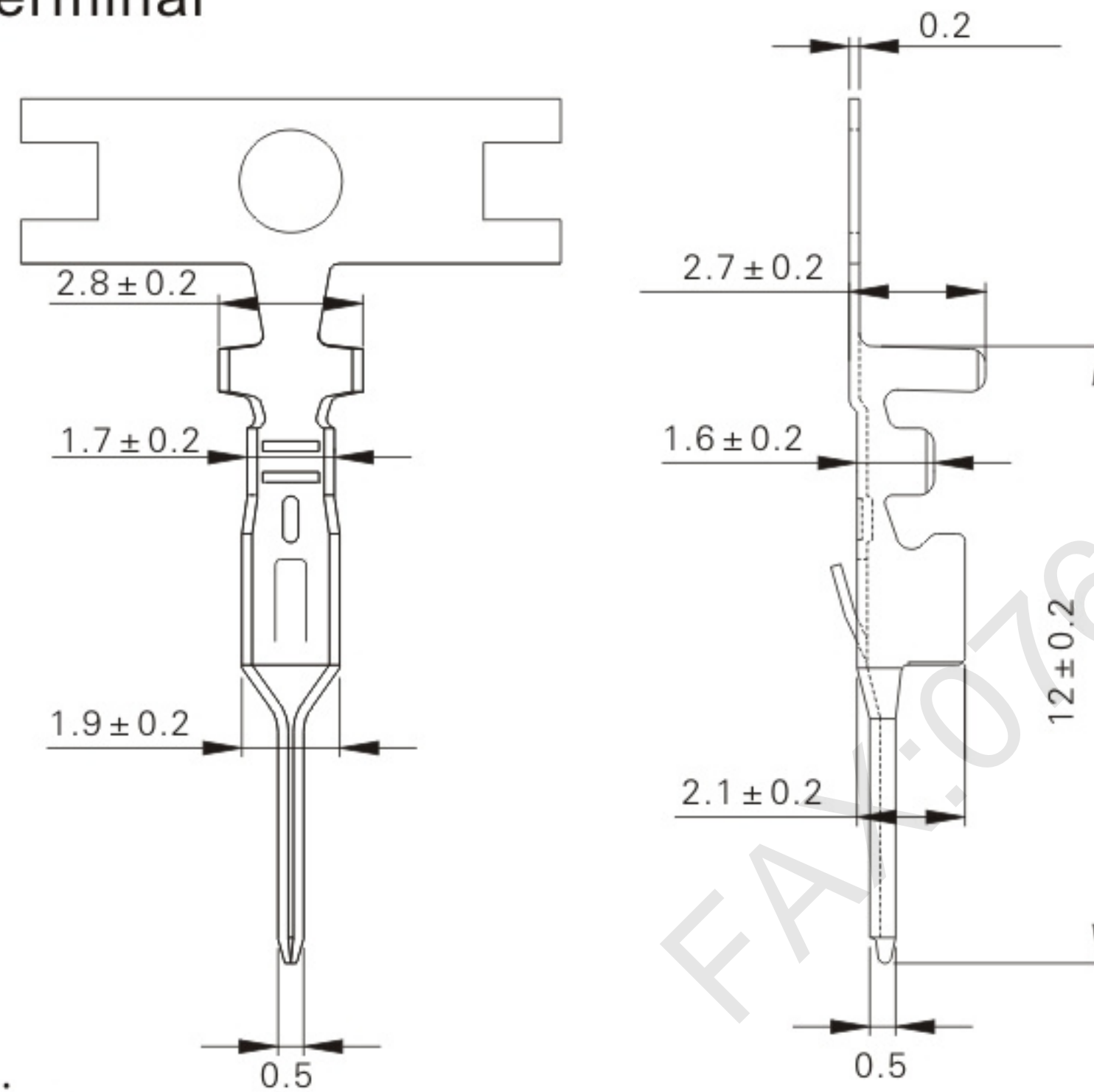

Ordering Information & Specifications

Unit: mm

Part No.	Wire Range	Insulation O.D.	Material	Finish	Qty/reel
4001MCT	AWG#22-#28		Phosphor Bronze	Tin-plated	7,000

4001MCH-02 (3.50mm pitch crimp housing)

Reference Informations:

- *Mat'l: Nylon 66 UL94V-0
- *Mates With: 4001CT series Terminal
- *Mates With: 4001MH series Housing

